

D380 "TwinPack" Microinverter Installation

Enphase Microinverter Formats

The Enphase Microinverters are available in two enclosure designs. The M190 and M210 microinverters both use a single enclosure design, which contains one DC input section, one AC input section and one AC output cable per enclosure. For each M190 or M210 enclosure, the DC input section connects to the solar module connectors and the AC output cable connects to the adjacent microinverter's AC input section to create a continuous branch circuit.

The D380 TwinPack microinverter enclosure contains two DC input sections and a single AC connection section. There is no integral AC cable on the D380 TwinPack microinverter enclosure. The AC connection is accomplished with a separate AC trunk cable assembly as shown in the lower diagram below.

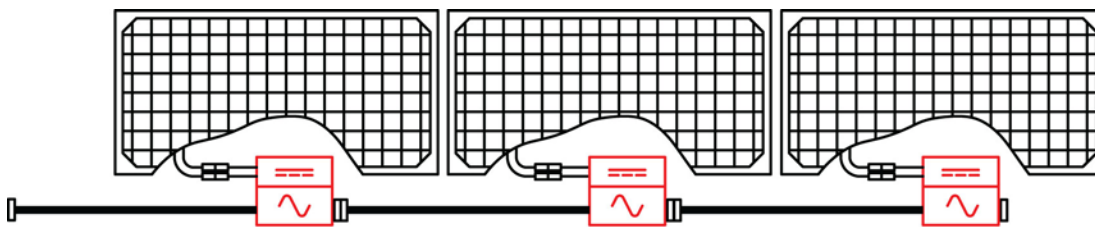

M190 Single Enclosure Connections

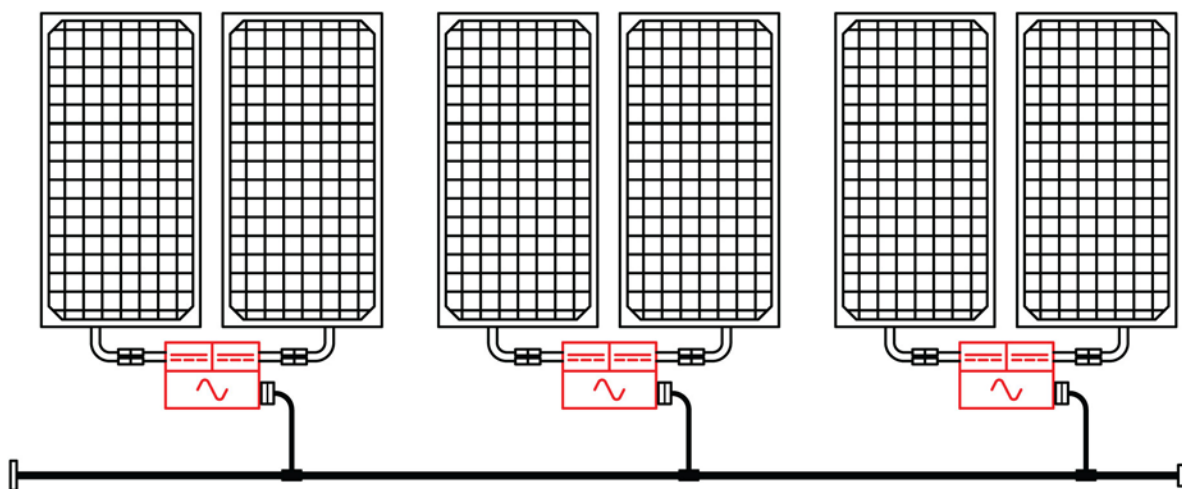

D380 TwinPack Enclosure Connections

D380 TwinPack Trunk Cable

The D380 TwinPack cable assembly is constructed with a 12 gauge trunk cable and three “drop” cables at the inverter locations. The drop cables are spaced at two module-wide intervals. TwinPack cable assemblies are connected end to end to create a branch circuit of the desired length. Dimensions of the cable assembly are shown below in inches.

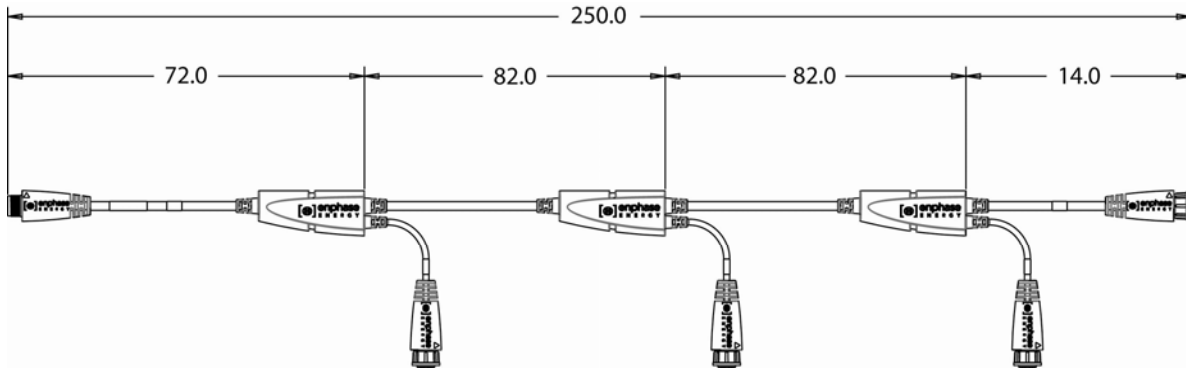

The 12 gauge trunk cable would be protected with a 20 amp circuit breaker allowing up to 33% more power per branch circuit, compared to branch circuits of the M190 and M210. A single 20 amp branch circuit would allow for up to 10 D380 TwinPack microinverters (20 PV modules) at 240 Vac, or 15 D380 TwinPack microinverters (30 PV modules) at 208 Vac. Different models of trunk cable are used depending on whether the installation is 240 Vac or 208Vac.

Each branch circuit of D380 TwinPack microinverters requires an AC interconnect cable, as well as an end-cap for the unused end of the last cable. The AC Interconnect cable is available in 6, 12, or 20 foot lengths.

AC Interconnect Cable

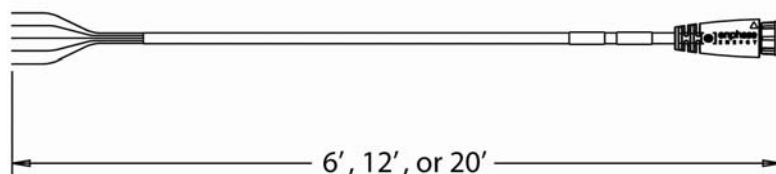

Portrait Module Orientation

D380 TwinPack microinverters mount to the module racking below one of the associated PV modules. The TwinPack cable is fastened to the module racking.

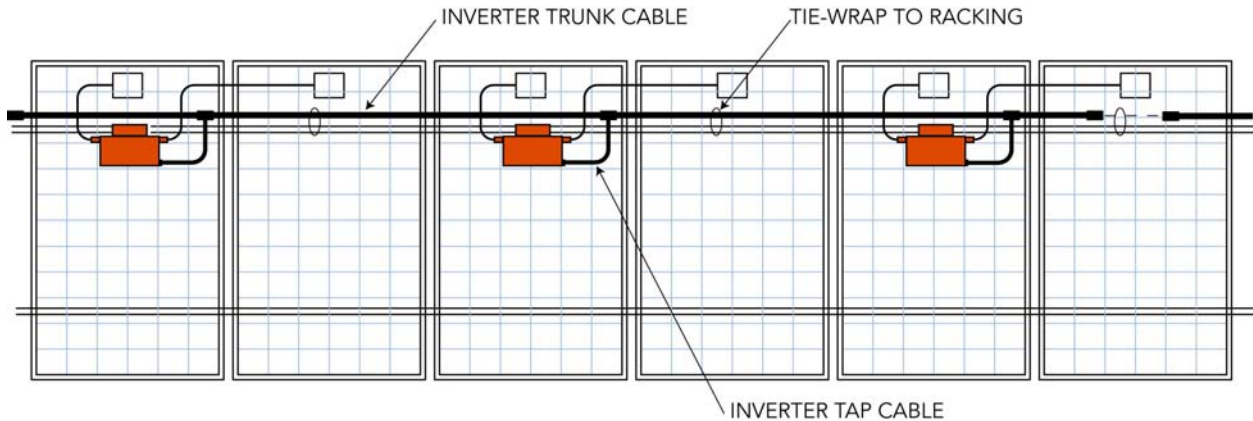

Landscape Module Orientation

For PV modules installed in landscape orientation, the D380 TwinPack microinverters could be mounted to the vertical module supports as shown. The spacing between drops on the cable is intended for two rows of PV modules.

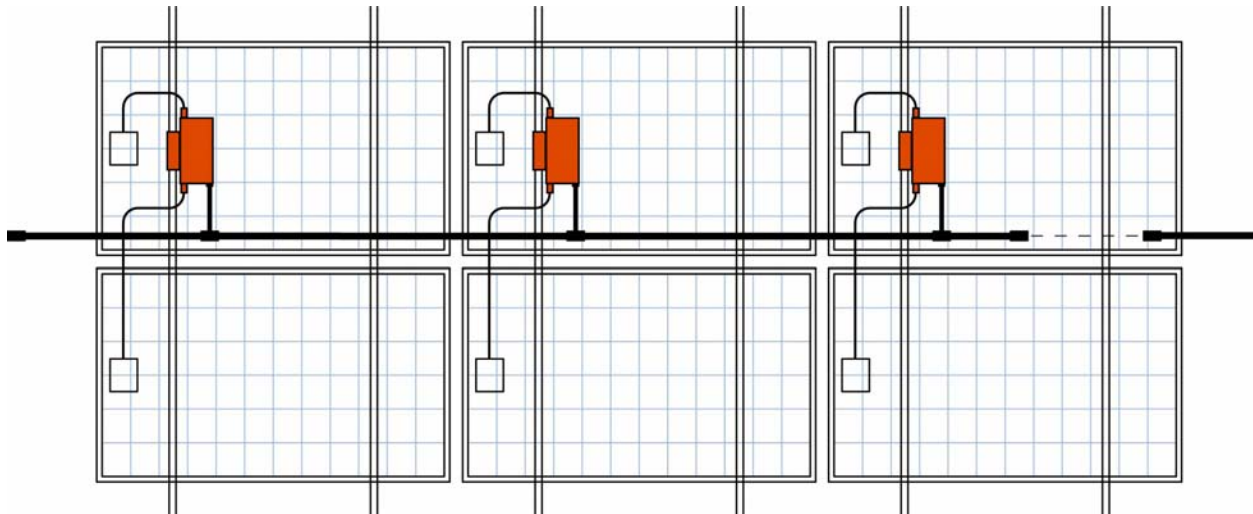

Note on Module Connection

If the branch circuit has an odd number of solar modules, be sure to connect the "A side" of the microinverter to the one remaining module.

Single-Drop Cables & End-Caps

Depending on the number of D380 units in the branch, you may need to use a “single-drop” cable to connect the final D380 microinverter to the branch. The single-drop cable connects to the end of the last trunk cable assembly, which eliminates the need for an end-cap.

Single Drop Trunk Cable

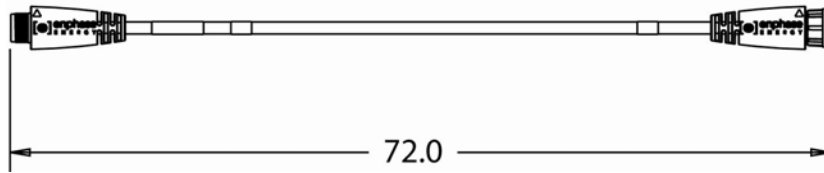

Alternatively, if you have two D380 units to connect to the end of the branch, you will need two end-caps: one to cover the one unused drop on the three-drop cable and one to cover the unused end of the three-drop cable.

This table provides detailed information on the possible branch configurations and the number of end-caps and single-drop cables that would be needed.

Number of D380's	Number of Modules	Single Drop Cable	Three Drop Cable	End-caps
1	2	1	0	0
2	4	0	1	2
3	6	0	1	1
4	8	1	1	0
5	10	0	2	2
6	12	0	2	1
7	14	1	2	0
8	16	0	3	2
9	18	0	3	1
10	20	1	3	0
11*	22	0	4	2
12*	24	0	4	1
13*	26	1	4	0
14*	28	0	5	2
15*	30	0	5	1

* Only applies to 208 Vac configurations.